

## ProAct™ ISC Integrated Speed Control

### Electric Actuator with Integral Speed Control or Position Driver

#### Applications

The ProAct™ Integrated Speed Control (ISC) is an electric actuator with an integrated electronic driver capable of diesel or gaseous engine speed control or positioning tasks. The ProAct ISC can be mounted on-engine to control a diesel fuel rack or gaseous throttle via linkage or integrated throttle body. The ProAct ISC accepts a speed input from an MPU and can accept a position command signal from another device in the system such as an engine control module.

Configured as a speed control, the ProAct ISC offers speed control with software-selectable speed set points, dynamics, fuel limiting, and start/stop behavior.

Configured as a positioner, the ProAct ISC offers position control with software selectable CW/CCW operation and field calibration.

#### Description

The ProAct ISC can be base- or flange-mounted on-engine, and will withstand high levels of vibration and temperature. The output shaft is a 0.625-36 serrated tooth shaft. Four levels of output torque are available. The ProAct ISC will also mount directly to Woodward integrated throttle bodies. The control accepts a speed input signal from a variable reluctance speed sensor, commonly called an MPU. The control may also be user-configured as a positioner accepting an analog position command signal or a J1939 CAN demand signal. Future options will include a CANopen communication capability.

The ProAct ISC offers a wide variety of speed control features: Dynamics settings, dual rated speed setting, idle/rated speed setting, raise or lower speed modifier, analog input speed modifier, analog raise and lower speed modifier, droop, dual dynamics, analog outputs, and discrete outputs.

The control also allows isochronous load sharing, and monitors key internal and external signals, and annunciates any detected faults through a discrete output. An analog output provides actual position indication, and a discrete input is available to remotely shut down the control.

Additional features of the ProAct ISC include on-line and off-line diagnostics, current limiting based on driver electronics temperature, and service port communications. The control is field programmable, allowing a single design to be used in many different applications. It must be configured and calibrated to the specific engine with a personal computer (PC) and the ProAct ISC Service Tool that communicates serially to the control via RS-232 using Woodward's DDE ServLink protocol. The ProAct ISC Service Tool can be downloaded from the Woodward website ([www.woodward.com/software](http://www.woodward.com/software)).

Refer to manual 26246 for more detailed information on the ProAct Integrated Speed Control.



- Extremely fast, bi-directional electric actuator, electronically positioned in both directions
- All-electric actuator requires no drive or hydraulic supply
- Integral driver compatible of recip engine speed control or positioning tasks
- 75° (±2°) rotary output allows direct coupling to butterfly, eliminating linkage
- Four actuator sizes to fit broad range of applications
- Configurable parameters to tailor to varied applications
- Advanced Diagnostics

## General Specifications

Actuator Model	Weight	Torque Output		Maximum Input Power		Maximum Current	
		Transient	Steady State	Transient	Continuous	Transient	Steady State
<b>Model I</b>	10.9 kg 24 lb	2.6 N·m 23 lb-in	1.3 N·m 11.5 lb-in	67 W	36 W	3.5 A	2 A
<b>Model II</b>	10.9 kg 24 lb	5.2 N·m 46 lb-in	2.6 N·m 23 lb-in	251 W	65 W	11 A	3.5 A
<b>Model III</b>	14.5 kg 32 lb	10.4 N·m 92 lb-in	5.2 N·m 46 lb-in	282 W	73 W	21 A	6.5 A
<b>Model IV</b>	21.8 kg 48 lb	20.8 N·m 184 lb-in	10.4 N·m 92 lb-in	371 W	101 W	21 A	6.5 A

## End User I/O Description

	Speed Control Configuration	Positioner Configuration
<b>Power Input</b>	18–32 Vdc	18–32 Vdc
<b>Command Input</b>	MPU (Magnetic Pickup) frequency input. 1–60 Vrms. 1–24 kHz	Analog: 4–20 mA 0–5 Vdc ±3 Vdc
<b>Position Feedback Output</b>	Available, see Analog Output below. 4 mA and 20 mA corresponds to 0% and 100% actuator position.	Available, see Analog Output below. 4 mA and 20 mA corresponds to 0% and 100% actuator position.
<b>Analog Inputs</b>	4–20 mA, 0–5 Vdc, ±3 Vdc	See Command Input
<b>Analog Outputs</b>	1 Available. 4–20 mA, 450 Ω load	1 Available. 4–20 mA, 450 Ω load
<b>Discrete Inputs</b>	5 Available. Software selectable High / Low or Active Open / Closed	5 Available. Software selectable High / Low or Active Open / Closed
<b>Discrete Output</b>	1 Available. Low side switch. 0.5 A	1 Available. Low side switch. 0.5 A
<b>RS-232 Serial Communications</b>	Used for Service Tool Communications. Integral with main connector.	Used for Service Tool Communications. Integral with main connector.
<b>CAN 2.0B Serial Communications</b>	Available for Boost Fuel Limit function	Hardware installed, future availability

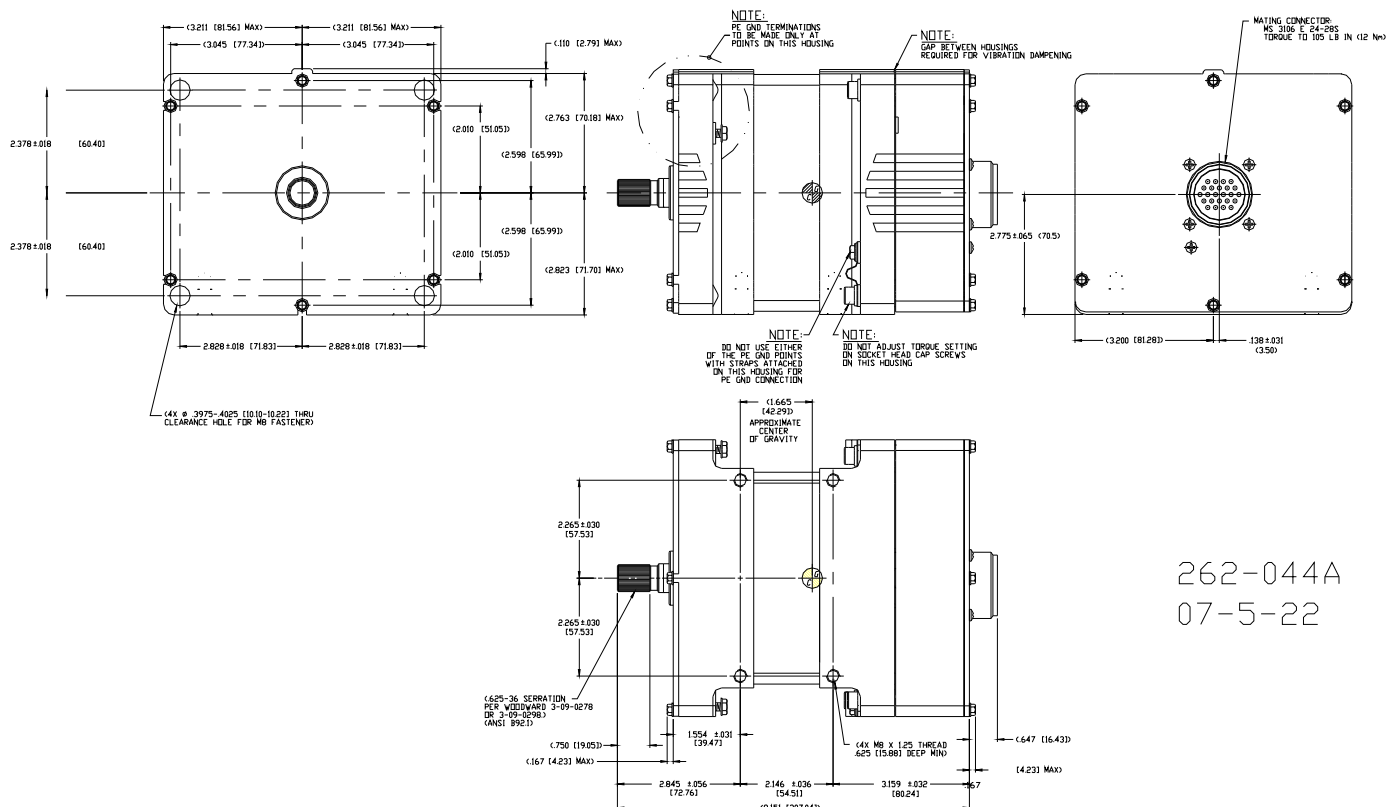

ProAct Integrated Speed Control, Models I and II

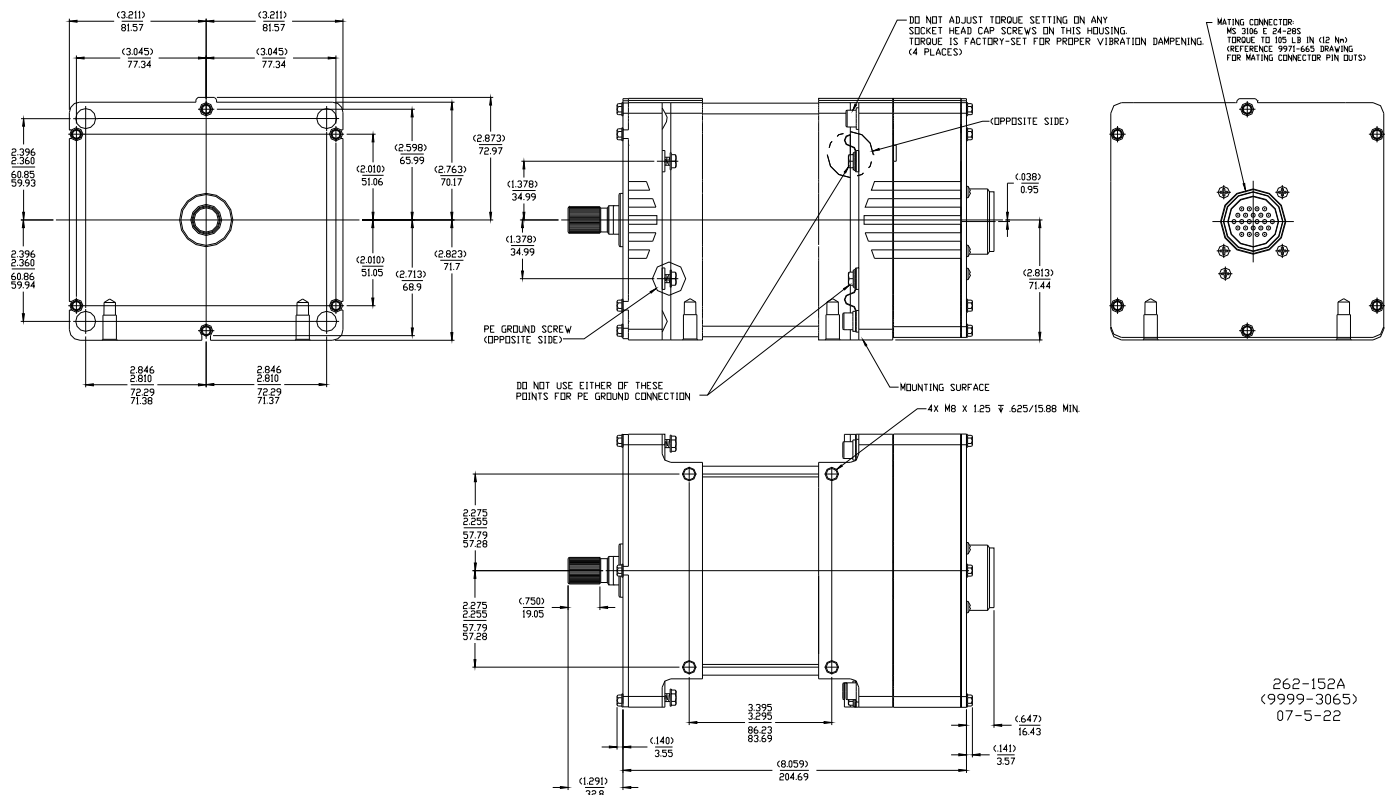

**ProAct Integrated Speed Control, Model III**

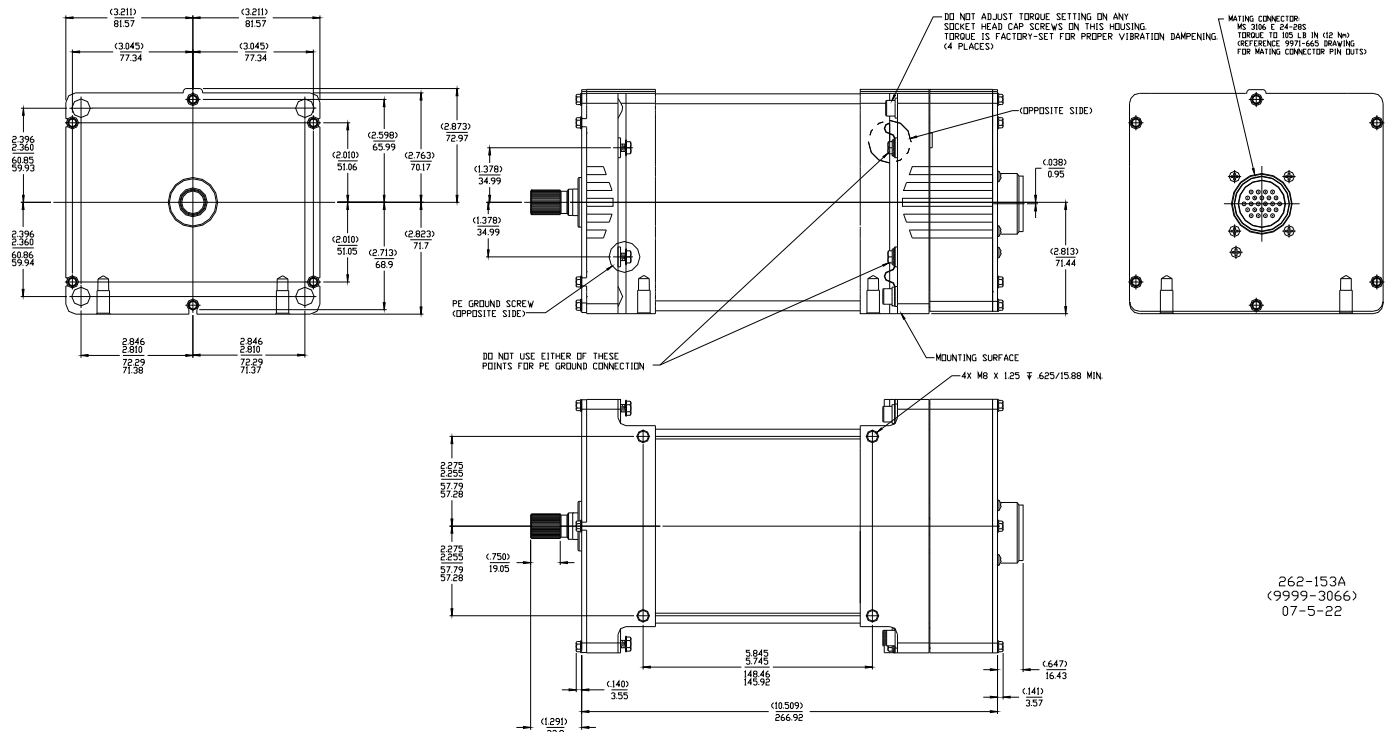

**ProAct Integrated Speed Control, Model IV**  
(Do not use for construction)

See manual 26246 for more detailed drawings.

## Environmental Specifications

---

Specification Item	Acceptable Range or Qualification Condition
Operating Temperature Limits	-40 to +85 °C
Storage Temperature	-40 to +125 °C, unpowered
Vibration Qualification Test	RV2: US MIL -STD-202F, procedure 214A: 0.1 G <sup>2</sup> / Hz, 10–2000 Hz, 3 hr /axis, 12.8 Grms Swept Sine 5–25 Hz, ±1.6 mm, 25–100 Hz ±4.0 G
Thermal Shock Qualification Test	Reference: SAE J1455, Paragraph 4.1.3.2 50 cycles from -40 to +125 °C. Unit unpowered.
Ingress Protection	IP56 per EN 60529:1992.
Humidity Qualification Test	60 °C, 95% RH for five days at one cycle per day.
Chemical Resistance	The actuator uses materials proven capable of withstanding normal engine environment chemicals per SAE J1455, such as diesel fuel, engine oil, and antifreeze.

## Performance Specifications

---

Parameter	Specification
<b>Max Slew Rate</b>	> 1000 degrees/second > 18.5 rad/s (10% to 90% travel)
<b>Position Control Accuracy</b>	±3% of full scale
<b>Steady State Speed Band</b>	0.5% of rated speed

## Regulatory Compliance

---

### CE Compliance:

- Compliant with EMC and Machinery Directives

### Agency Listings:

- CSA Class I, Division 2, Groups A, B, C, and D per CSA for Canada and US or non-hazardous locations only.
- Type 3R Enclosure Rainproof

## Customer Electrical Connections

---

### ProAct ISC

The ProAct ISC is equipped with a 24 pin MS-style connector.