

# DSLCTM

## Digital Synchronizer and Load Control

### Applications

The Woodward DSLCTM control is a microprocessor-based synchronizer and load control designed for use on three-phase AC generators equipped with Woodward or other compatible speed controls and compatible automatic voltage regulators. The DSLC control is a synchronizer, a load sensor, a load control, a dead bus closing system, and optionally a VAR/PF and process control, all integrated into one powerful, yet convenient package.

The DSLC control provides either phase matching or slip frequency automatic synchronizing. The DSLC control talks over its own LON (Local Operating Network using Echelon LonWorks®\* network technology) to enable safe dead bus closing, and ties into your automatic voltage regulator to match voltages before paralleling.

The DSLC control senses true RMS power and provides bumpless loading and unloading functions. It can either base load or set import/export/process power levels against the utility, and through the DSLC control's LON, accurately share loads on isolated, multi-engine systems.

The optional VAR/PF control is flexible enough to allow you either to provide a set level of VARs to the utility (if this is economical) or to maintain a constant power factor for reliable operation. Through the LON, the VAR/PF control also shares power factors in isolated systems, maintaining proportional reactive loads (kVARs) on all machines more accurately than droop or cross-current voltage systems.

### Advantages

- Reduces wiring between synchronizer, load control and automatic loading controls
- Having functions integrated into one box eliminates the need for redundant sensors (like PTs, CTs, and MOPs) that connect to individual modules such as the load sensor and synchronizer
- Hand Held Programmer reduces installation and calibration time by allowing the user to set up the control prior to starting the system
- Hand Held Programmer lets operator monitor generator parameters, contact switches, and analog I/O for installation and troubleshooting
- Reduces the amount of cabinet space needed
- Eliminates the need for additional relay logic or a PLC to control dead bus closing
- Digital communications across the LON reduce susceptibility to noise on the load sharing lines
- Slip frequency paralleling, voltage matching, and speed bias transfer between the synchronizer and load control result in smooth paralleling without the risk of reverse power trips
- Three-phase true RMS power sensing makes the DSLC control accurate even with unbalanced phase loading and voltage fluctuations
- Can load share with Woodward analog controls when used with the Load Sharing Interface Module (8239-082). Refer to Woodward Manual # 02031 for details.

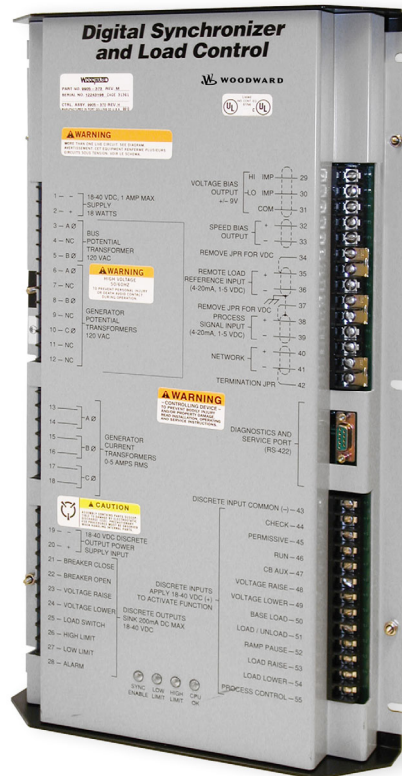

- Synchronizer and load control in one box
- Automatic generator loading and unloading for bumpless load transfer
- Isochronous load sharing with other DSLC-equipped sets
- Process import/export control
- VAR or Power Factor control
- Dead bus closing
- Accurate control of non-linear and distorted generator wave forms
- Digital communications network for information exchange between controls
- Programmable load switch or reverse power trip output
- UL and cUL Listed

\*-LonWorks is a trademark of Echelon Corporation.

## Operating Modes

**Isolated Bus**—The DSLC control talks over its LON to share proportional real and reactive loads. Real load (kW) is controlled using percentages of full load for each machine, and reactive loads (kVAR) are shared by matching power factors. The DSLC control maintains a specified bus voltage and frequency while balancing loads.

**Utility Parallel**—The DSLC control measures real load (kW) on the generator and adjusts the speed control to match a set base load, or to control a process at a user-chosen, externally adjustable set-point. It can be set to a constant import/export level using an MSLC ( Master Synchronizer and Load Control). The DSLC control can also measure and maintain a set reactive load (kVAR) or can maintain a user-prescribed power factor.

**Transition Between Modes**—The DSLC control will ramp at a user-chosen rate from one mode to another until the control is within 5% of its target. It then shifts into dynamic control, allowing bumpless operating mode changes. In addition, the DSLC control automatically changes its VAR/PF mode when the real load mode is changed to or from an isolated load sharing application. Manual VAR/PF control may also be selected.

## Adjustments

The Woodward Hand Held Programmer makes all adjustments quickly and easily, through the control's ten convenient "menus". The control saves all set points in permanent memory, which does not require batteries or other power sources to retain data. The Hand Held Programmer prevents tampering with set points, yet allows entries to be changed at any time. The Hand Held Programmer displays in plain English, so there are no codes to look up or memorize.

- Menu 1—Synchronizer Functions
- Menu 2—Load Control Functions
- Menu 3—Process Control Functions
- Menu 4—VAR/Power Factor Control Functions
- Menu 5—Configuration
- Menu 6—Calibration
- Menu 7—Generator Electric Parameters
- Menu 8—Control Status Monitor
- Menu 9—Discrete Inputs/Outputs Monitor
- Menu 0—Diagnostics

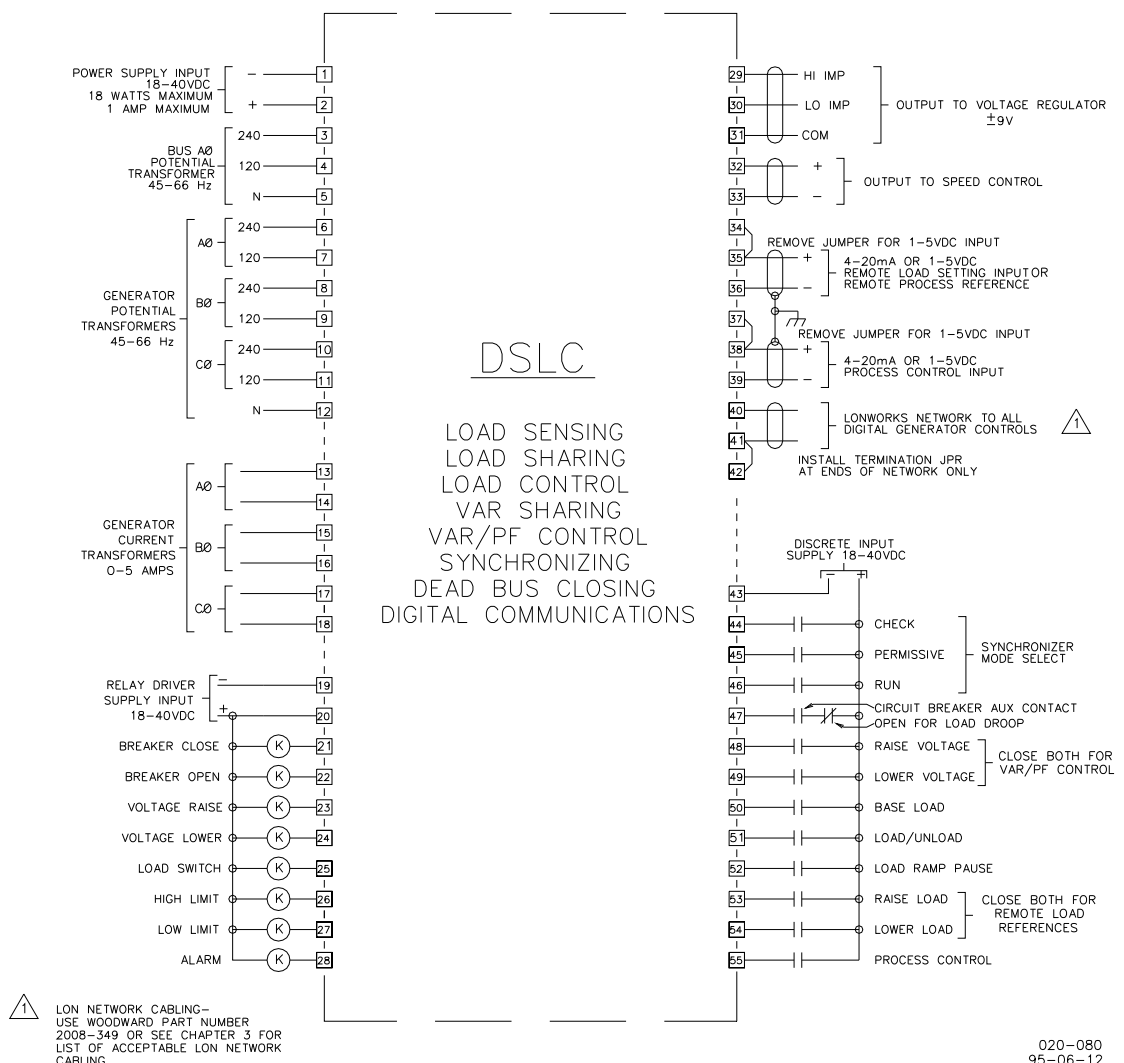

**Typical Wiring Connections**  
(120/240 V wye switchgear configuration)

## Specifications

### Environmental Specifications

Operating Temperature.....	-40 to +70 °C (-40 to +158 °F)
Storage Temperature.....	-55 to +105 °C (-67 to +221 °F)
Humidity.....	95% at 38 °C
Electromagnetic Susceptibility .....	ANSI/IEEE C37.90.2; ANSI C37.90.1-1989
Mechanical Shock.....	US MIL-STD 810C, Method 516.2, Procedures I, II, V
Vibration.....	US MIL-STD 167, Type I

### Electrical Specifications

#### Control Power Supply Input

Operating.....	8–32 Vdc continuous (as low as 10 Vdc, 1.8 A max, or as high as 77 Vdc for up to 5 min)
Reverse .....	-56 Vdc continuous
Burden .....	18 W, 1 A max.

#### Voltage Sensing Inputs

120 Vac Input (L-N) Wye PT Configuration.....	65–150 Vac, terminals 4–5, 7–12, 9–12, and 11–12
240 Vac Input (L-N) Wye PT Configuration.....	150–300 Vac, terminals 3–5, 6–12, 8–12, and 10–12
120 Vac Open Delta PT Configuration.....	65–150 Vac, terminals 3–5, 6–8, 8–10 and 10–6
240 Vac Open Delta PT Configuration.....	150–300 Vac, terminals 3–5, 6–8, 8–10, and 10–6
Phases.....	Three phase generator bus, single phase parallel bus
Frequency.....	45–66 Hz
Burden .....	Less than 0.1 VA per phase
Accuracy .....	0.1% of full scale

#### Current Transformer Inputs (CTs)

Current.....	0–5 Arms, 7 Arms max.
Frequency.....	45 to 66 Hz
Burden .....	Less than 0.1 VA per phase
Accuracy .....	0.1% of full scale
Phases.....	Three phase generator bus
Discrete Inputs.....	18–40 Vdc @ 10 mA
Analog Inputs.....	4–20 mA @ 243 Ω or 1–5 Vdc @ 10 kΩ
Analog Outputs.....	Speed Bias: ±2.5 Vdc, 0.5–4.5 Vdc, 1–5 Vdc across 243 Ω, or 500 Hz PWM Voltage Bias: high in ±9 Vdc, low in ±3 Vdc, current 50 mA
Relay Driver Outputs.....	18–40 Vdc @ 200 mA sink
Local Operating Network .....	Echelon LonWorks Technology, Standard Protocol, 1.25 MBPS
Calibration and Diagnostics Port.....	RS-422

### Compliance

UL/cUL.....	Listed
-------------	--------

Technical Manual..... 02007

Upgrade Level*	Voltage Input	PT Configuration	Speed Bias	Part Number
Reduced	120/240	wye	0.5–4.5 Vdc	9905-354
Full	120/240	wye	0.5–4.5 Vdc	9905-355
Reduced	120	open delta	0.5–4.5 Vdc	9905-366
Full	120	open delta	0.5–4.5 Vdc	9905-367
Reduced	240	open delta	0.5–4.5 Vdc	9905-368
Full	240	open delta	0.5–4.5 Vdc	9905-369
Reduced	120/240	wye	1–5 Vdc	9905-711
Full	120/240	wye	1–5 Vdc	9905-603
Reduced	120	open delta	1–5 Vdc	9905-707
Full	120	open delta	1–5 Vdc	9905-708
Reduced	240	open delta	1–5 Vdc	9905-709
Full	240	open delta	1–5 Vdc	9905-710
Reduced	120/240	wye	+3.0 Vdc	9907-007
Full	120/240	wye	+3.0 Vdc	9905-795
Reduced	120	open delta	+3.0 Vdc	9905-796
Full	120	open delta	+3.0 Vdc	9905-797
Reduced	240	open delta	+3.0 Vdc	9905-362
Full	240	open delta	+3.0 Vdc	9905-363
Reduced	120/240	wye	500 Hz PWM	9905-798
Full	120/240	wye	500 Hz PWM	9905-799
Reduced	120	open delta	500 Hz PWM	9905-372
Full	120	open delta	500 Hz PWM	9905-373
Reduced	240	open delta	500 Hz PWM	9905-374
Full	240	open delta	500 Hz PWM	9905-704
		Hand Held Programmer		9907-205

\*–The reduced upgrade level DSLC part numbers do not have power factor control or process control functions. The reduced DSLC units are intended for applications which do not require integrated power factor or process control.

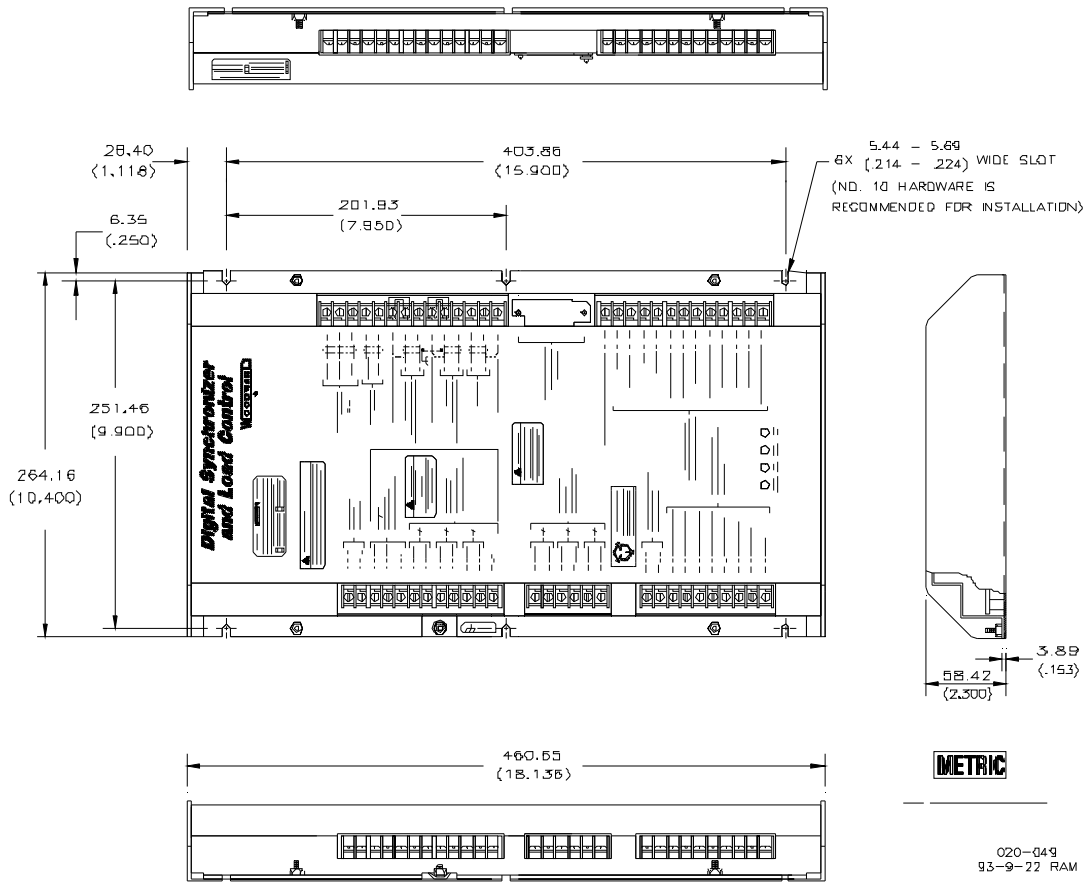

**DSLC Control Outline Drawing (Do not use for construction)**

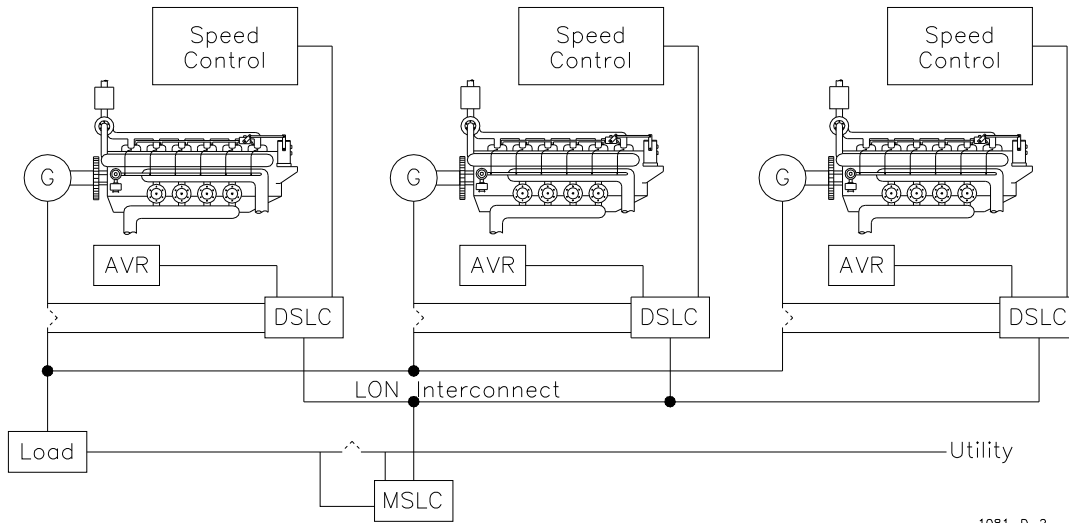

**DSLC Control in a Parallel Bus/Utility Parallel Application with an MSLC (Master Synchronizer and Load Control)**

1081-D-2  
97-07-08